

**Rittal – The System.**

Faster – better – everywhere.

# The future is sustainable

Efficient liquid cooling



ENCLOSURES

POWER DISTRIBUTION

CLIMATE CONTROL

IT INFRASTRUCTURE

SOFTWARE & SERVICES

FRIEDHELM LOH GROUP



# Efficient and precise – The benefits of liquid cooling

---

The smooth-running of many industrial manufacturing processes depends on the cooling of liquids. Control cabinets and machine tools in particular must maintain an exact temperature for precise operation.

Liquid cooling is a particularly efficient solution for numerous applications, thanks to its great flexibility and capacity to dissipate high heat loads from equipment using water.



Up to **70%**   
**energy cost savings**  
with **Blue e+ chillers**

# Contents

---

Our solutions are user-friendly and easy to assemble, offering maximum reliability. Even customised technical solutions are rapidly available off the shelf and from volume production. What's more, we have made a priority of key aspects such as sustainability and eco-friendliness.

<b>Brief presentation</b>	
Integrated process cooling – One system for all industries	<b>4</b>
<b>Efficient engineering with Eplan software tools</b>	<b>6</b>
<b>Individual configuration and design</b>	<b>8</b>
<b>Approvals give access to international markets</b>	<b>10</b>
<b>Air/water heat exchangers</b>	<b>12</b>
For wall mounting or roof mounting	<b>14</b>
LCP – Liquid Cooling Package	<b>16</b>
<b>Chillers – Precise and efficient</b>	<b>18</b>
Setting up and installation options	<b>20</b>
Blue e+ chillers with the e+ principle	<b>22</b>
Blue e chillers	<b>24</b>
VX25 TopTherm chillers	<b>26</b>
Preconfigured chiller options for greater flexibility	<b>28</b>
<b>In practice</b>	
50 percent less energy consumption: Bosch Rexroth	<b>30</b>
Satisfied customers are our best endorsement: AXA, Renault, FHWS	<b>32</b>
<b>Rittal Service</b>	
International service – Global availability	<b>34</b>
Rittal after sales service – for industrial applications	<b>36</b>
Service agreements – Individual and customisable	<b>38</b>
Rittal Smart Service – Maximum availability, unrivalled efficiency	<b>39</b>
<b>Ordering information</b>	<b>40</b>

# Integrated process cooling – One system for all industries

---

Each industry has its own requirements. Take advantage of our proven track record and expertise from countless international projects. Efficient, reliable process cooling solutions from Rittal provide measurably enhanced benefits, even for specialist applications.



## Machine tools

Application areas: High-speed spindles, torque engines, drive shafts, enclosures

- Bi-frequency design ensures international compatibility
- Energy efficiency due to smart control
- Minimal footprint due to flexible mounting system



## Welding technology

Application areas: Welding electrodes

- Integration into welding robots for a compact design
- Nano-coated condenser ensures a high MTBF
- The option of integrating into the machine control system guarantees high energy efficiency levels and a long service life



## Laser technology

Application areas: High-performance lasers and optics

- Innovative control concept with precise temperature hysteresis, due to integrated PID controller
- Adjustable hydraulic system with piping made from plastic, stainless steel or copper
- Compact design for versatile machine integration options

### **Foods and packaging**

Application areas: Foil wrapping machines, punching stations for blister packs and blow-moulding machines

- Stainless steel enclosures meet all required hygiene standards
- Water-carrying parts made from stainless steel
- Nano-coated condenser ensures a high MTBF



### **IT infrastructure**

Application areas: Racks, rack suites, server rooms

- High energy efficiency (EER) due to free cooling and inverter-regulated pumps
- Redundant power systems (pump, compressors etc.) guarantee a high MTBF
- Universal interfaces offer exceptional reliability: SNMP, BACnet etc.



### **Electronics/power distribution**

Application areas: Enclosures, frequency converters, high-performance engines, measurement systems, generators

- Cooling output range from 0.3 to 10 kW
- Extensive choice of water connection options
- High level of reliability, due to leak monitoring
- Cooling at high ambient temperatures up to +70 °C



# Efficient engineering with Eplan software tools

---

Together, Rittal and Eplan offer integrated, seamless solutions spanning every stage of the value chain, from engineering, to manufacturing, through to maintenance and repair. Eplan software tools provide a consistent database saving time in day-to-day operations. They simplify design planning by providing end-to-end, validated CAD data for all Rittal components. The outcome is an engineering project with maximised planning certainty.

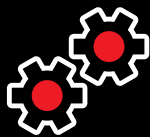

**43% efficiency gain** – that’s the estimated potential of an integral engineering software solution, according to a recent customer survey.

“Enclosure manufacturing 4.0” study by Stuttgart University

Project-plan your liquid cooling with the following Eplan solutions:



- **EPLAN Data Portal:** Rittal’s EPLAN Data Portal provides the relevant liquid cooling data. Pre-integrated electrical engineering macros and 3D data for enclosure assembly are enhanced with fluid-specific information. This also benefits users when planning climate control units and chillers.



- **EPLAN Fluid:** High-quality Rittal data from the EPLAN Data Portal may be transferred directly into the user’s fluid plans for cooling works. The EPLAN Fluid software generates fluid plans for cooling technology.



- **EPLAN Electric P8:** Conventional circuit diagrams are generated in EPLAN Electric P8, again based on high-quality Rittal data from the EPLAN Data Portal.



- **EPLAN Pro Panel:** From this consistent database, EPLAN Pro Panel supports 3D planning of the entire enclosure. In this way, users can collaborate with Rittal and Eplan to project plan the entire cooling system.





The benefits of the ongoing interplay between Eplan and Rittal solutions are particularly evident in the liquid cooling segment of the following industries:

- **Supply chains for a variety of industries:** Integrated project planning of liquid cooling in Eplan, combined with simple data integration for Rittal solutions, adds value throughout the value chain. This benefits players in various parts of the supply chain, such as in the automotive industry.
- **Machine manufacturers (OEMs):** For OEMs, the availability of consistent data cuts down on the workload. System selection is supported and the time spent on planning is reduced, as supplier documentation is readily merged with the end clients' standards.
- **Plant operators:** All works relating to control engineering, including cooling as an element of fluid engineering, are combined into one Eplan project. This also helps to streamline maintenance and repairs. Plant operators also benefit from comprehensive documentation.





Up to **40%**  
**time savings**  
with planning

**Rittal – The System.**  
Faster – better – everywhere.

### Welcome to the Chiller Configurator

This Configurator is a cost-effective way of designing your required machine and process cooling. Cooling output, volumetric flow and coolant temperatures are precisely tailored to the required level of your application. The choice is yours!

Contact | Imprint / Terms and Conditions  
English

Would you like to calculate the heat loss?

Medium outlet temperature in °C  *i* Medium inlet temperature in °C  *i*

Volumetric flow in l/min  *i*

Do you already know the heat loss?

Heat loss in kW (1 - 41)

POWER DISTRIBUTION → CLIMATE CONTROL → IT INFRASTRUCTURE → SOFTWARE & SERVICES



# Individual configuration and design

The best design, control and monitoring of the installation are critical for efficient climate control. We support you with user-friendly tools and software for rapid calculation, plus Web-based tools and interfaces to easily control your climate control solution.

## Chiller configurator

- Automated, cost-effective design of the required cooling output
- Rapid selection of a suitable chiller in the 1 to 50 kW output range
- Drawings for quote preparation or engineering can be downloaded in any preferred format via Cadenas.

[www.rittal.com/chiller-configurator](http://www.rittal.com/chiller-configurator)

## Therm software

- Automated calculation of your climate control requirements
- Easy-to-use interface
- Delivers suitable, correctly dimensioned climate control components

[www.rittal.com/therm](http://www.rittal.com/therm)

## Performance diagrams / pump characteristics / resistance diagrams

The various performance diagrams can be found in the operating instructions or on our website under the relevant product.

## Technical details

Join our Rittal part community and download the latest drawings. You can choose between a wide range of CAD formats.

[www.rittal.de/partcommunity](http://www.rittal.de/partcommunity)

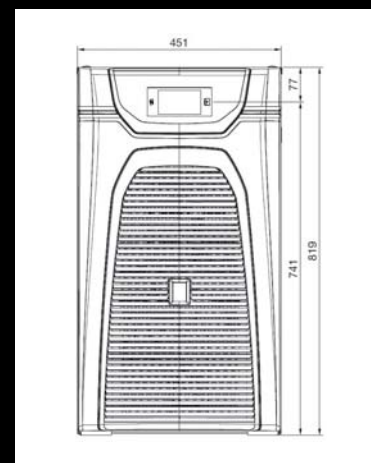
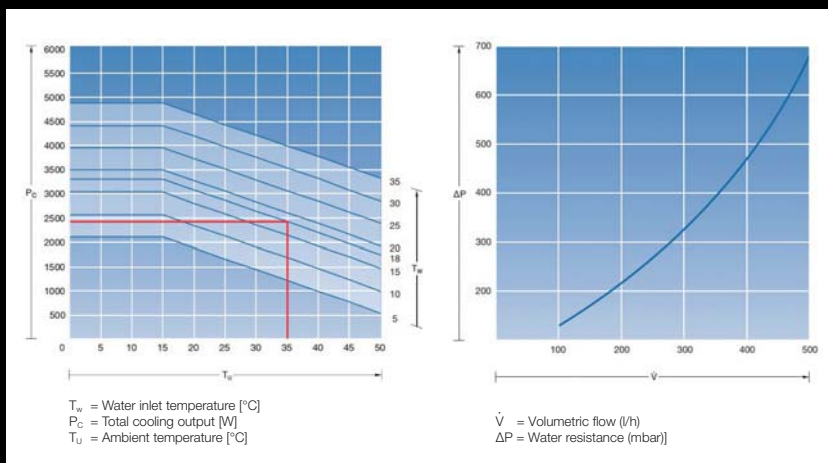

# Approvals give access to international markets

---

Rittal products meet the highest internationally recognised quality standards.

- All components undergo the most stringent testing in line with international standards and regulations
- The consistently high product quality is ensured by a comprehensive quality management system
- Regular production inspections by external test institutes guarantee compliance with global standards

All current approvals and certifications can be found on the Rittal website.



# 100%

**tested** and  
**standardised quality**

### **IECEE CB procedure (CB procedure)**

The CB procedure was devised by the International Electrotechnical Commission for Electrical Equipment (IECEE). It is derived from internationally recognised standards and based on a global network of national CB testing laboratories (CBTLs).

The national CB laboratories test product safety and issue manufacturers with a CB test report and CB test certificate, allowing them to submit fast-track applications for the relevant conformity marks or approvals of other countries or target markets. This makes international marketing much easier.

**Rittal climate control components such as roof-mounted fans, Blue e+ cooling units and Blue e+ chillers are certified under the CB procedure.**



### **CE label and approvals**

All products subject to labelling under an EU Directive are labelled "CE". In this way, Rittal ensures that its products are compliant with all applicable standards and guidelines. Details of product safety regulations are published in the appropriate operating manuals. The declarations of conformity for each product can be downloaded from the Rittal homepage. The CE symbol is not a quality symbol. Conformity is certified as the manufacturer's own responsibility.

#### **Note:**

Countless Rittal products boast internationally recognised approvals. These products carry a rating plate showing the serial number and approval symbol such as UR/cUR, UL/cUL, UL/cUL-FTTA, CSA and EAC etc., which is classed as proof of approval. Whether a product has approvals, and if so which ones, can be viewed online in the product segment.



# Air/water heat exchangers – Efficient and ambient air-neutral

---



For use at **ambient**  
**temperatures** of up to **+70 °C**



Cooling water from a central recooling system is used to cool the temperature inside the enclosure to below the ambient temperature. The ingress of external dust into the cooled enclosure is prevented.



If the heat exchanger and cold water supply system are physically separated, waste heat from the enclosure will not increase the ambient temperature. Air/water heat exchangers can also be used at extreme ambient temperatures ranging from +1 °C to +70 °C. Even extreme levels of contamination in the ambient air, e.g. with dust and oil, do not affect functionality. High heat loads are dissipated in the most confined spaces. A high operating ratio is achieved, thanks to the large surface area of the heat exchanger unit and the powerful EC fan technology.

**Important note: Air/water heat exchangers should always be used in conjunction with recooling systems (chillers) or an existing cooling water circuit.**



Air/water heat exchangers for wall mounting, 0.3 to 7 kW



Air/water heat exchangers HD for wall mounting, 0.6 to 1.2 kW



Air/water heat exchangers for roof mounting, 1.87 to 4 kW



Liquid Cooling Package (air/water heat exchanger in the bayed enclosure system, 9.5 kW)

### The benefits for you:



- Also available with all water-carrying parts made from stainless steel
- High protection category IP 55 to IEC 60 529
- Virtually maintenance-free
- Regulation of the air and water circuit is electronically monitored
- Air/water heat exchangers are also available in Hygienic Design for use in hygiene-critical production zones in the food and beverage industry

# Compact and lightweight for space-saving installation

## Air/water heat exchangers for wall mounting or roof mounting

Air/water heat exchangers have a low weight and a comparatively low volume relative to the heat loss to be dissipated. Consequently, they are easily mounted on vertical enclosure surfaces or on the roof.

### Enhanced reliability and a long service life

For undefined cooling media, or even well water, air/water heat exchangers are available with all water-carrying parts made from stainless steel 1.4571 (V4A). Corrosion is virtually eliminated.



### The benefits for you:

- Various water connection options
  - 1/2" connector sleeve
  - Fixed connection with G3/8" external thread
  - Fixed connection with G3/8" internal thread (accessories)
- Flexible installation options
- Integrated leak monitoring ensures comprehensive functional reliability
- 2 control options with Basic and Comfort controller
- Energy-efficient eco-mode control
- International approvals (UR, cUR, cULus, FTTA and CSA)



## Meticulously designed options

### ■ Wall mounting

For mounting on the wall or any sufficiently large vertical surface

### ■ Roof mounting

Especially for bayed enclosures where wall-mounted devices would obstruct the door



### More effective cooling with targeted air routing for roof-mounted versions

Cool air from the heat exchanger is routed precisely to the relevant assembly via an air duct system.

## Different options

### Basic controller

- The current enclosure internal temperature and all system messages are presented on the display
- Setpoint adjustment (setting range +20 °C ... +55 °C)
- Switching hysteresis: 5 K
- Floating fault alarm relay (overtemperature and undertemperature warning)
- Condensate warning/leak monitoring (only with roof-mounted cooling units)



### e-Comfort controller – Additional functions compared with the Basic controller:

- Switching hysteresis: 2 K ... 10 K; preset to 5 K
- Two floating fault alarm relays (normally open contacts) to which system messages may be assigned
- Condensate warning/leak monitoring for wall-mounted and roof-mounted units
- Master/slave function for up to 10 units
- All system messages are readable using RiDiag diagnosis software
- Energy-efficient eco-mode control
- Temperature control via internal fan is supported (magnetic valve permanently open)



### Application example:

Parallel connection of air/water heat exchangers with cold water supplied via a recooling system. Overflow valves and bypass control should be integrated into the recooling system / the customer's own pipeline system respectively.

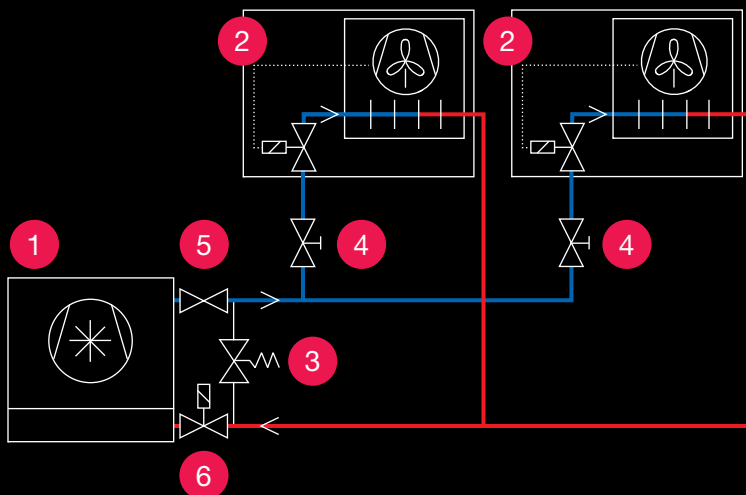

- 1 Recooling system
- 2 Air/water heat exchanger
- 3 Overflow valve (bypass function with the magnetic valve of the air/water heat exchanger closed), Model No. 3301.900/.910/.920
- 4 Flow regulator valve (to regulate the volume flow for air/water heat exchangers)
- 5 Non-return valve (optional)
- 6 Magnetic valve (optional)

# The flexible, powerful industry solution

## LCP – Liquid Cooling Package delivers maximum performance in a minimised space



The separation between cooling and enclosure prevents water from penetrating the enclosure, and makes it very easy to assemble and service. Based on very positive experiences with IT cooling, Rittal has developed the high-performance LCP Industry (Liquid Cooling Package) especially for use in industrial environments. The LCP Industry is easy to handle and can be transported in lifts and through doors. The low weight means a minimal floor load. Among industrial applications, there is a growing demand for air/water heat exchangers with a cooling output range of up to 10 kW.

Alongside their high cooling output, another major benefit of these heat exchangers is that they can be easily and fully integrated into the Rittal VX25 baying enclosure system.

The heat exchanger can be fitted into the enclosure system or be externally mounted which gives extra and greater flexibility. Depending on the required cooling output, air may be routed to one side on the left or right or (if positioned centrally) on both sides.

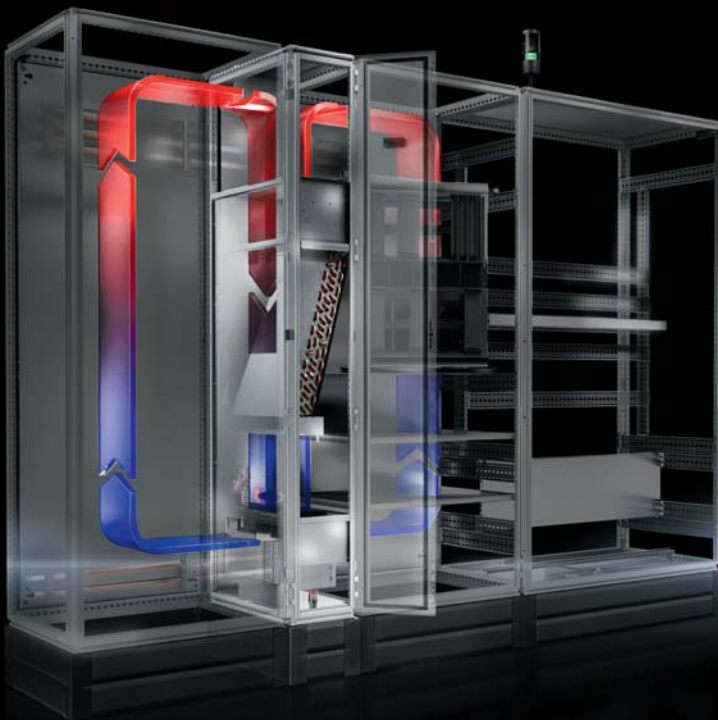

### The benefits for you:



- Virtually maintenance-free operation
- Minimum noise emissions
- Lower operating costs than compressor cooling units
- Compact design
- Water connection options on the top and bottom of the unit



## LCP – Liquid Cooling Package for industry

### A convincing climate control option

#### ■ Fits perfectly into the system

Bayable to all 600 or 800 mm deep, 2000 mm high VX25 enclosures

#### ■ Maximum performance in a minimum space

Air outlet with either 5 kW on both sides or 10 kW on just one side

#### ■ Flexible water connection

Flexible water connection options are available on the top or bottom of the unit

#### ■ Flexible applications

Busbars and cables are easily routed through the unit at the top and bottom. This means that even bayed enclosure suites can be supplied with a high cooling output.

#### ■ Energy efficiency

EC fans and Comfort controllers for even greater efficiency



The heat exchanger can be easily fitted into the enclosure system or externally mounted.



Busbars and cables are easily routed through the unit.

## Variable baying options

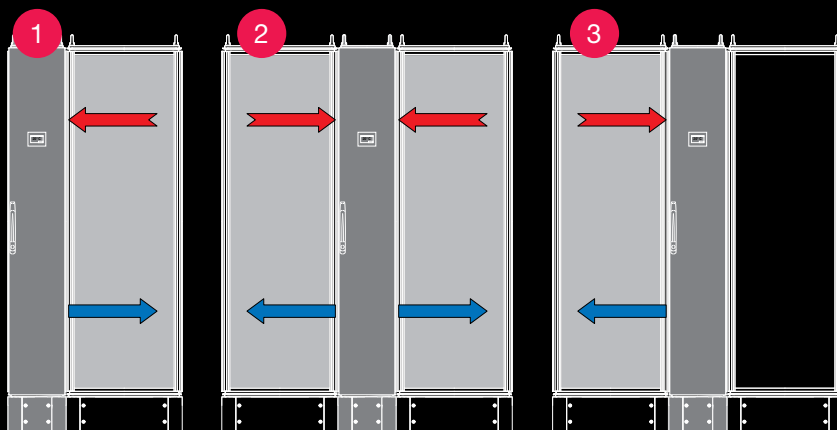

**1** At the beginning or end of a enclosure suite, air routing on one side

**2** Within an enclosure suite, air routing on both sides

**3** Within an enclosure suite, air routing on one side, optional sealing of air inlet and outlet openings with metal covers

# Chillers – Precise and efficient

---

Up to **70%**   
energy savings



Chillers provide centralised, efficient cooling and supply of the cooling medium (generally water). They are ideal for use with particularly high heat loads. All the cooling needs of the system or machine are delivered via a single pipeline system. At the same time, the chillers also physically separate refrigeration and process cooling, thereby facilitating parallel, efficient supply to multiple items of equipment.

**Does your application have special requirements?  
If so, please talk to us!  
We will be happy to prepare a customised quote for your project solutions.**



TopTherm chiller, Mini  
1 to 1.5 kW



Blue e+ chillers  
2.5 to 5.5 kW



Blue e chillers  
8 to 50 kW



TopTherm chillers, VX25  
8 to 20 kW

## The benefits for you:



### Fast

- Save time when selecting and ordering your add-on packages with our user-friendly configurator and fast, off-the-shelf delivery
- The availability of all data and macros in EPLAN Data Portal and EPLAN Fluid as well as in CADENAS enables simple, fast project planning

### Precise

- Precision cooling as standard guarantees a high level of machining accuracy
- Rittal chillers boast exceptional temperature accuracy

### Reliable

- Conformity with international standards and regulations supports global use
- Rittal's dependable worldwide service network and the global availability of spare parts create a fail-safe solution
- Remote tracking via the IoT interface makes monitoring easy

### Efficient

- High energy efficiency means a reduced carbon footprint and lower energy costs
- Microchannel technology uses less refrigerant

# Setting up and installation options

## Perfect placement of air/water heat exchangers and chillers

### For installation and commissioning, please note

- Connection of an inlet and outlet duct requires the manufacturer's prior consent.
- Never site the chiller near a heater.
- The chiller may only be sited on flat, solid surfaces. The maximum permissible deviation from the vertical is 2°.
- Use insulated pipe or hose connections to connect the equipment to the chiller.
- If the equipment is positioned higher than the chiller: Install a non-return valve in the inlet and a magnetic valve in the return to prevent the tank from overflowing.
- For chillers intended for covered outdoor siting, the minimum exterior temperature is given in the technical specifications.
- In the case of chillers (for water) at temperatures below zero, a water/glycol mixture should be added in the prescribed ratio.
- If it is possible to shut off the equipment cycle, a bypass must be provided to protect the pump.
- Under no circumstances must the circulation pump be allowed to run dry – this will damage the pump.

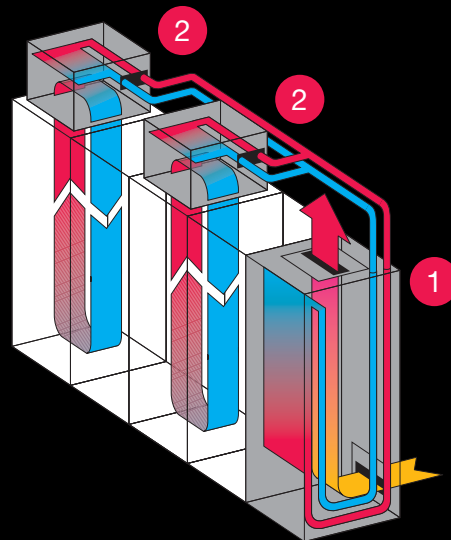

- 1. Chiller
- 2. Air/water heat exchanger, roof-mounted

### In harmony with enclosures

- Chiller systems may also be connected directly to a bayed enclosure suite, providing effective, centralised cooling for all enclosures and cabinets.
- Chillers in VX25 enclosures may be integrated into existing enclosure combinations. Roof-mounted chillers, with their space-saving, compact design, are ideal for applications in confined spaces.



### Physically separated

- Physical separation of the chiller from the enclosures and equipment allows high heat loads to be dissipated, even in confined and awkward spaces. In all cases, alongside enclosure cooling, cooling water may be produced for process and machine cooling or for cooling liquid media.
- With their robust industrial enclosures, chillers are the ideal stand-alone solution.

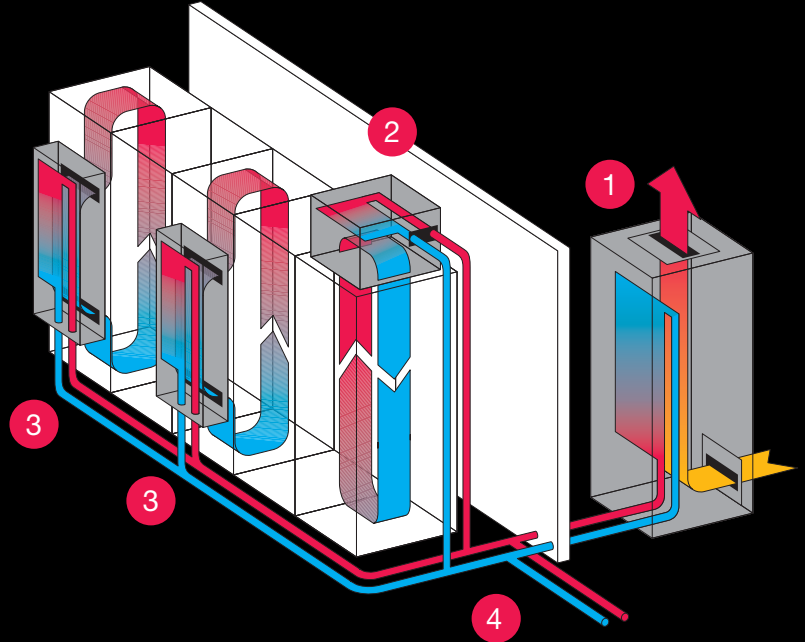

### Outdoor siting

- To avoid polluting the factory air with the waste heat generated during the process, we can supply chillers with the option of outdoor siting (for ambient temperatures up to  $-20\text{ }^{\circ}\text{C}$ ).
- In such cases, a rain canopy should be provided to protect the chiller from extreme weather. A dedicated outdoor cooling medium in a premixed ratio of 1:2 must be added to the water circuit, to provide additional frost protection up to  $-20\text{ }^{\circ}\text{C}$ .

- 1. Chiller
- 2. Air/water heat exchanger, roof-mounted
- 3. Air/water heat exchanger, wall-mounted
- 4. Other cooling options, e.g. machine cooling

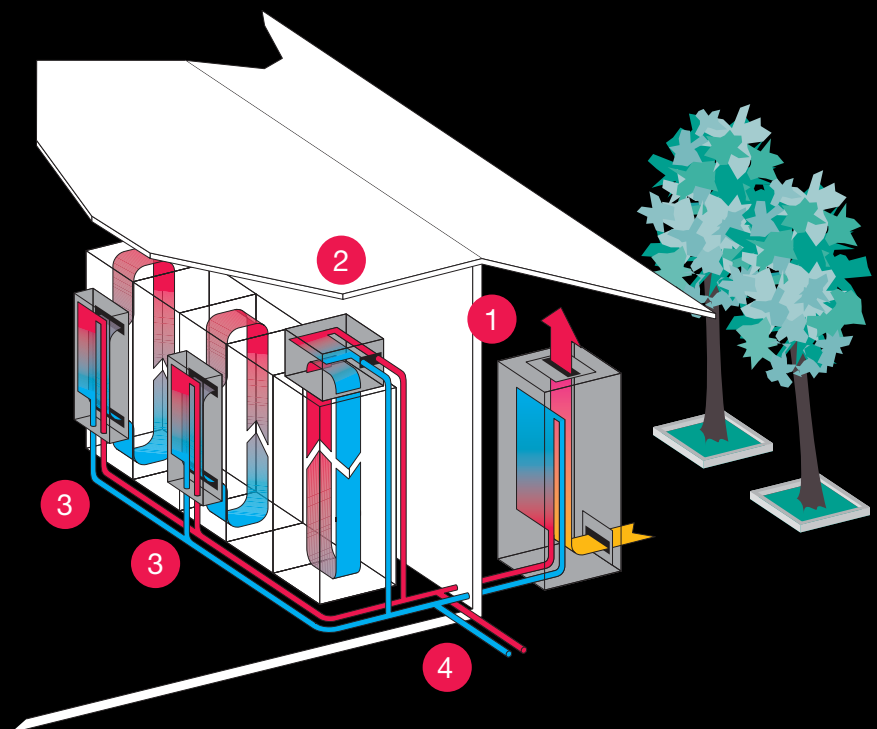

# Efficient. Flexible. Compact.

## Blue e+ chillers with the e+ principle

Blue e+ chillers are efficient, flexible and compact. They provide central, cost-effective chilling of the cooling water and are used to supply air/water heat exchangers etc. Energy savings of up to 70% are possible, thanks to speed-regulated components and inverter technology. International approvals and multi-voltage capability make these chillers suitable for worldwide use. Intuitive operation via touch display and smart communications interfaces ensure user-friendly operation and analysis.



Up to **70%**   
**energy cost savings**

### The benefits for you:

- Central, efficient cooling of liquid media with a high level of temperature accuracy
- Unique multi-voltage capability supports global use
- Integrated overflow valve and monitoring sensors for maximum reliability
- Intuitive operation with touch display
- Compact, modular layout for a minimal footprint
- Pumps with highly efficient IE3 motors

### Intelligent networking

In conjunction with the IoT interface, all Blue e+ chillers can now be networked and digitalised.

### The benefits for you:

- Continuous monitoring of temperature accuracy
- Avoidance of downtime costs and consequential damage
- Temperature records and energy efficiency analyses
- Enhanced process reliability
- Fast, user-friendly configuration and commissioning via the integrated web server, no programming required

### Progressive climate control

- Active cooling circuit with speed-controlled components for demand-based cooling
- Excellent operational reliability thanks to integrated flow sensor, overflow valve and electronic fill level monitoring
- DC inverter technology with two control modes ensures a high level of control accuracy
- Temperature limits from -5 °C to +50 °C
- Microchannel technology uses 55% less refrigerant
- Energy savings of up to 70%

### Easier to operate

- Fast unit analysis using RiDiag III software via the USB port
- Fast parameterisation, data reading and plain-text system messages on the smart, multilingual, industry-grade display (21 languages pre-installed)



### Maximum flexibility with assembly and siting

- Simple plug & play assembly
- Identical footprint for all power options
- Eyebolts for easier transportation
- Service-friendly with optimum access to all components
- Easy replacement of components

### For global use

- One device for all voltages and networks:
  - 380 to 415 V, 3~, 50 Hz
  - 440 to 480 V, 3~, 60 Hz
- International approvals: cULus Listed, EAC, CB report
- Pre-configured option packages



Reinforced pump



Special paint

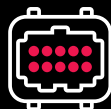

Industrial connector

The options (reinforced pump, special paint and industrial connector) have been retrospectively tested and certified by UL, enabling export to the US market for these versions.

# Exceptionally efficient, demand-based cooling output

## Blue e chillers

The Blue e chiller in the floor-standing enclosure delivers centralised, efficient chilling of the cooling water. The microchannel technology reduces the volume of refrigerant required. Intuitive operation via the touch display and smart communication interfaces support user-friendly operation and analysis. Integrated safety features, included as standard, ensure maximum safety.

**40%**  
less **refrigerant**



### The benefits for you:

- Microchannel technology reduces the volume of refrigerant required
- Touch display for simple user prompting
- Smart interfaces
- Integrated safety functions
- Pre-configured options





### Simple user prompting

- Fast parameterisation, data reading and plain-text system messages on the smart, multilingual, industry-grade touch display
- Prioritised error messages with three escalation levels (warning, error, maintenance)

### Targeted climate control

- Central activation of the fan and compressor via a digital controller
- Hysteresis with precision controller (HGBP)  $\pm 0.25$  K

### Sustainable and eco-friendly

- Microchannel technology uses 40% less refrigerant
- No galvanic corrosion, as the microchannel heat exchanger is made from 100% aluminium

### Simple assembly

- Plug & play
- Fully wired ready for connection
- Service-friendly with optimum access to all components

### Integrated safety features

- Overflow valve
- Flow monitor
- Fill level and phase rotation monitoring
- Pre-installed external NTC sensor for ambient temperature regulation

### Pre-configured options

- Available off the shelf as standard
- Performance-enhanced pumps broaden the range of applications still further
- Precision control (HGBP) improves regulatory accuracy from  $\pm 2$  K to  $\pm 0.25$  K
- Control voltage 24 V DC, e.g. for use in automotive applications



Data reading and system messages on the touch display

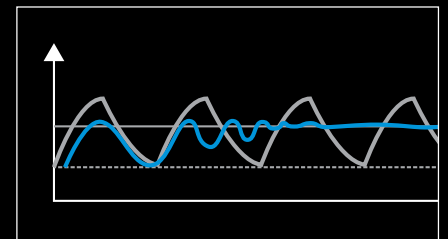

Hysteresis with precision controller

### Also available as an add-on package:

Shorter delivery times and a streamlined ordering process



Heater

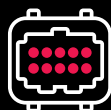

Industrial connector



Precision controller



Special paint



Reinforced pump



Outdoors (up to  $-20$  °C)



Laser application



Water-cooled condenser

**The chiller is also available with UL-approved components.**

# Perfect integration into bayed enclosure suites

## VX25 TopTherm chillers

VX25 TopTherm chillers are compact in design yet have a wide range of cooling applications. They fit perfectly with all enclosures; they have a minimum footprint; promise increased efficiency; are instantly available from stock.

### The benefits for you:



- Up to 35% smaller CO<sub>2</sub> footprint
- Microchannel technology reduces the volume of refrigerant required
- Improved system protection with increased safety features
- Minimum footprint
- A single housing size for four output classes
- Extremely maintenance-friendly



40%

less **refrigerant**



**Carbon footprint**  
is reduced  
by up to **35%**



34%

smaller **footprint**



### More user-friendly

- Fast parameter set-up, data readout as well as system and error messages in plain text on the smart, multi-language industrial-grade touch display
- Simple configuration with the chiller configurator
- Predefined options shorten delivery times
- Suitable for global use with a dual-frequency power supply

### Sustainable technology

- Proven energy savings with the carbon footprint reduced by up to 35%
- Microchannel technology uses 40% less refrigerant
- Eliminates the need for an annual leak test thereby significantly reducing maintenance costs

### Perfect integration

- Integrated into the VX25 baying system and therefore perfect for baying in an enclosure suite
- 20 kW output category on a footprint of just 0.48 m<sup>2</sup>
- One enclosure system for four output classes (8 to 20 kW)
- Compatible VX25 system accessories for assembly, baying and attachment

### Enhanced safety

- Integrated safety functions (overflow valve, flow monitor and fill level and phase rotation monitoring)
- Pre-installed external NTC sensor for ambient temperature regulation
- Extended component life and high levels of machining accuracy with precise temperature control ( $\pm 1$  K)
- Smart interfaces to support remote monitoring

### High levels of operational uptime

- Fast delivery off the shelf
- Qualified service technicians help to minimise downtime and boost efficiency
- Excellent availability of original spare parts and 24-hour contactability
- Optimum accessibility due to modular design



# Preconfigured chiller options for greater flexibility

---

Our chiller solutions can serve a wide range of applications. Whatever your circumstance, we have a suitable chiller available. Preconfigured options mean shorter delivery times and a streamlined ordering process.

## Choose from:



### Reinforced pump

- For applications requiring a higher flow rate or pressure of the pump cooling medium, the pump can be designed in a higher performance option.



### Speed-controlled pump

- The cooling medium pump may be designed as a speed-controlled pump, whose speed is regulated depending on the actual cooling medium requirements and adapted to the existing hydraulic system.
- Low energy consumption
- Pressure is adjusted automatically to the existing system.



### Oil / emulsion

- Low-viscosity oil or emulsion may also be used as a cooling medium instead of the water-glycol mixture used as standard.
- If using the oil/emulsion option as a cooling medium, the chiller will operate as a once-through cooler.



### Integral free cooler

- The “Free Cooling” option allows you to cool without an active refrigerant circuit in so-called hybrid mode.
- Energy efficiency can be improved still further with an integrated free cooler, particularly if the chiller is sited outdoors, thus achieving a high Delta T during the winter months.



### Water-cooled condenser

- A water-cooled condenser emits waste heat to the existing cooling water network. This prevents the waste heat from the process from being emitted directly into the environment and raising the ambient air temperature.



### Laser

- With pipework free from non-ferrous metals, deionised water may be used as the cooling medium.



### Connections (industry connectors)

- With this connection interface you can define your mains and communication connection cable.

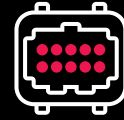

### Outdoor siting

- The “Outdoor” option boasts a special spray-finish allowing the chiller to be sited outside.
- For outdoor siting, the customer should provide a rain canopy to protect the chiller from downpours.



### Heater

- A tank heater may be installed to pre-heat the cooling medium or for frost protection.



### Special paint

- If a special spray finish is required, customers can choose from the standard RAL colour shades.
- The device zone (built-in display element) will remain in the standard colour RAL 7016.



### Precision controller

- For superior medium control accuracy to  $\pm 0.25$  K



### Anti-overflow kit

- In case of height differences (where the chiller is lower than the equipment), a non-return valve is installed in the inlet and a solenoid valve in the return of the cooling medium circuit to prevent the tank from overflowing.



### Monitoring

- Remote monitoring via Ethernet interface



### Multi-circuit systems

- The pump output in the second water circuit is 2 bar/30 – 55 l/min



# 50% less energy consumption: Bosch Rexroth

---

Never underestimate the energy requirements of machine tools. Cooling the enclosure and spindles accounts for a huge 15% of energy demand. A test installation in a CNC lathe at Bosch Rexroth found that the new Blue e+ chillers from Rittal achieved a significant reduction in energy consumption.



---

The Blue e+ chillers from Rittal use 50% less electricity than our old re cooler. The results are even more impressive with the enclosure cooling unit, with savings of more than 80%. This example illustrates the huge untapped potential in many areas.

---

Leo Pototzky, GoGreen Project Manager, Bosch Rexroth

Long-established Bosch Rexroth AG operates the energy efficiency consultancy firm GoGreen from its headquarters in Lohr am Main. It is tasked with analysing the global energy efficiency potential of the company's own production plants and formulating appropriate responses. GoGreen collaborates with a number of institutes and technology partners including Rittal. One of its flagship projects is the Eta factory (energy efficiency, technology and application centre), managed by the Institute of Production Management, Technology and Machine Tools (PTW) at Darmstadt Technical University. The research facility replicates a process chain originating from the Rexroth plant in Elchingen. Work is underway to translate the research findings into practice. One of the multiple strands of this project focuses on the energy efficiency of machine tools.

## **Upgrading CNC lathes**

The Bosch Rexroth factory in Elchingen manufactures, amongst other things, hydraulic pumps and motors for mobile machine tools. Various components for the hydraulic units are produced on a CNC lathe. This project entailed retro-fitting a CNC lathe with a new Blue e+ chiller from Rittal. The machine has a total connected output of 75 kVA and operates in three-shift mode up to six days per week.



The energy consumption before and after the upgrade was documented in detail to enable the research team to precisely quantify the improvement in energy efficiency.

The spindles of machine tools for machining metal generally need to be cooled to dissipate the heat produced by the drive technology. This is achieved with liquid cooling. The cooling solution was provided by the Rittal Blue e+ chiller after upgrading the CNC lathe. In the chiller, an inverter-regulated DC compressor delivers the required cooling output. A circuit transports the cooling medium to the equipment such as the spindles. The existing compressor cooling unit was replaced with a device from the Blue e+ range to achieve effective cooling of the machine tool enclosure.

### **Impressive energy efficiency gains**

These new energy-efficient units significantly reduce energy consumption. The new chiller consumes more than 50% less electricity than the previous cooling solution. For enclosure cooling units, the savings are even higher (more than 80%). Another important aspect is that the units are simple to operate: The control panel with touch display shows all messages in plain text, optionally in 21 different languages. All key information and status messages are presented quickly and clearly to enable an immediate response from the operator. The Blue e+ app, which communicates with equipment via NFC (Near Field Communication, an international communication standard based on RFID technology for the contactless exchange of data) allows key data to be transmitted wirelessly. This is particularly important when configuring multiple chillers.







# Satisfied customers are our best endorsement

---

---

We were impressed by the outstanding energy efficiency of the new Rittal Blue e+ chillers, which is a significant improvement on predecessor versions.

---

Alexander Saar, Managing Director,  
AXA Entwicklungs- und Maschinenbau GmbH



---

The Blue e+ chiller helped us reduce our energy consumption by 50% compared with a similar competitor product.

---

Jonathan Bechez, Refrigeration Engineering Consultant  
at the Renault Le Mans plant



---

Our direct comparison of the new Blue e+ chiller with a hot gas bypass unit found that the EER increased from 2.62 to 4.49. In percentage terms, this equates to an impressive 71.37%. Over an operating period of 5,000 h, this means energy savings of more than 2,400 kWh, or €410 in monetary terms.

---

**FH·W-S**

Dipl.-Ing. (FH) Julian Müller, Research Assistant at the Würzburg-Schweinfurt  
University for Applied Sciences.

# International service – Global availability

---

**Competent. Globally present. A one-stop service.**



# 24/7

**Rittal service**

for our customers.

Our service capability can help minimise downtime and boost your efficiency. Benefit from highly qualified service technicians and system specialists with dedicated manufacturer expertise. At 150 locations worldwide, we guarantee quick response times.

#### **The benefits for you:**

- Original spare parts are readily available
- Maximum plant availability
- Professional lifecycle management
- 24-hour accessibility

---

Whenever, wherever and however you need us,  
we are always at your service!

---

#### **What we offer**

- Assembly, installation, commissioning
- Fast trouble-shooting
- Inspection
- Professional maintenance
- Original spare parts
- Individual service contracts
- Efficiency and system consulting
- Individual optimisation and sustainability



# Rittal after-sales service – for industrial applications

---



## **Installation and commissioning**

Correctly installed devices are less susceptible to errors and operate more efficiently. Your Rittal components are always installed and commissioned using the manufacturer's expertise.

### **The benefits for you:**

- Reliability from day one
- Less susceptibility to errors
- Efficient operation of your systems

## **Maintenance, system check and leak test**

Professional maintenance by the Rittal service team can significantly extend the service life of installed components, and guarantees efficient operation as well as associated cost savings. The additional system check and leak test by certified service technicians guarantees compliance with the statutory requirements, such as the F-Gases Regulation (EU) No. 5174/2014, ensuring that your equipment operates efficiently.

Go directly to:

[www.rittal.com/f-gas-calculator](http://www.rittal.com/f-gas-calculator)

---

The Rittal F-Gas Calculator identifies the mandatory measures which the operator must implement to comply with the F-Gas Regulation.

---

### **The benefits for you:**

- Minimise risk by avoiding downtime
- Increase the value of your asset
- Compliance with statutory regulations and standards to DIN 31051:2012-09
- Up to 30% efficiency gains, plus associated cost savings
- Compliant performance as standard of legally binding leak tests
- Support with changing over to new and approved refrigerants



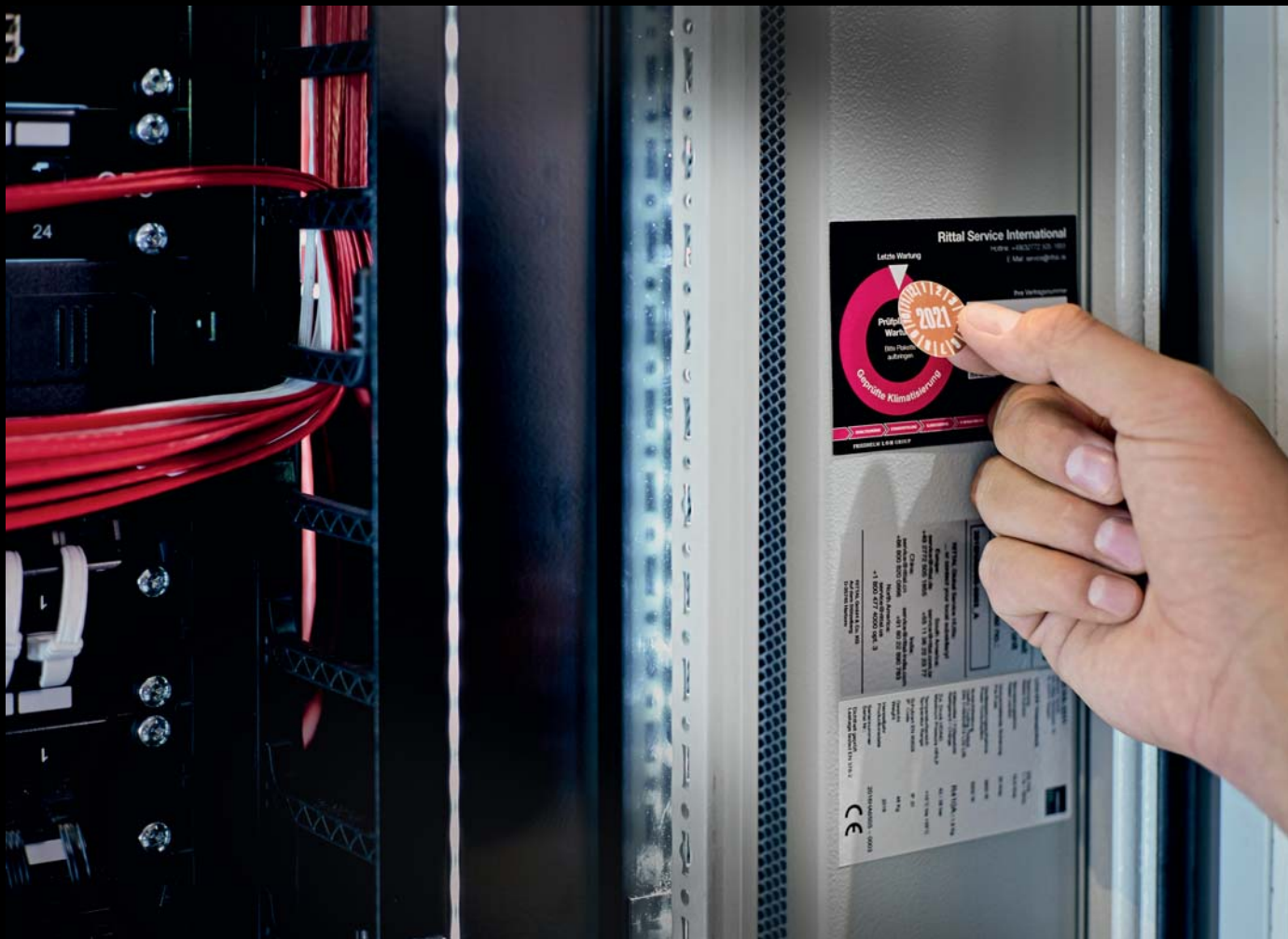

### Repairs and troubleshooting

Rittal service technicians undergo continuous training to provide high-quality, on-site troubleshooting. The result? 90% of Rittal's service call-outs are resolved in a single visit, and include a detailed service report including other recommendations. Alternatively, you can send your equipment to our factory for repair

#### The benefits for you:

- Fast, professional troubleshooting
- Minimum downtime
- Reliable service performance

---

RiDiag is a diagnosis software package for cooling units and chillers, designed to streamline maintenance and simplify the diagnosis of system messages.

---

Download free of charge from:  
[www.rittal.com/com-en/  
Software/RiDiag](http://www.rittal.com/com-en/Software/RiDiag)

# Service agreements – individual and customisable

Rittal service agreements allow you to tailor the scope of services to your specific requirements and pick and mix individual modules – based on fixed, transparent terms and conditions.

## The benefits for you:

- A high level of fail-safeness
- Plannable costs
- Guaranteed response times
- Warranty extension
- Individual stocking of spares



### Maintenance

Next week day (Mon–Sat) 7 am–5 pm	Within 4 hours
--------------------------------------	----------------



### Availability

Next working day (Mon–Fri) 7 am–5 pm	Working days (Mon – Fri) 24 hours	Every day (Mon – Sun) 24 hours
---	--------------------------------------	-----------------------------------



### On-site service

Next working day (Mon–Fri) 7 am–5 pm	Next week day (Mon–Sat) 7 am–5 pm	Within 8 hours	Within 4 hours
--	---	----------------	----------------



### Warranty extension

No contractual commitment Separate agreement	Contract extension +12/+24/+36 months	Preventive replacement of wearing parts +12/+24/+36 months
---	--	--



### Stocking of spare parts

Stocked at Rittal	Stocked at Rittal and delivered within 24 hours	Individually agreed stocking of spares
-------------------	--	---



### Inspection

1× per year	4× per year	12× per year
-------------	-------------	--------------

- Standard agreement
- Optional contract modules

# Rittal Smart Service – Maximum availability, unrivalled efficiency

## Increase cooling availability and optimise your service processes

Rittal Smart Service displays and monitors the operational performance of cooling units and chillers in the Blue e+ series. Real-time data transmission ensures that maintenance requirements are identified and any irregularities are promptly detected. The automated processing of the cooling unit's data allows fast, efficient troubleshooting.

### The benefits for you:

- Control of maintenance measures
- Display of the equipment's data via the Web portal (condition monitoring)
- Access to operating and temperature characteristics
- Overview of energy consumption & efficiency analyses
- Situation-specific recommendations based on manufacturer expertise

### How you benefit:

- Enhanced cooling availability
- Requirement-driven maintenance leads to more efficient servicing
- Fast problem analysis and troubleshooting with remote diagnosis

## Rittal Smart Service

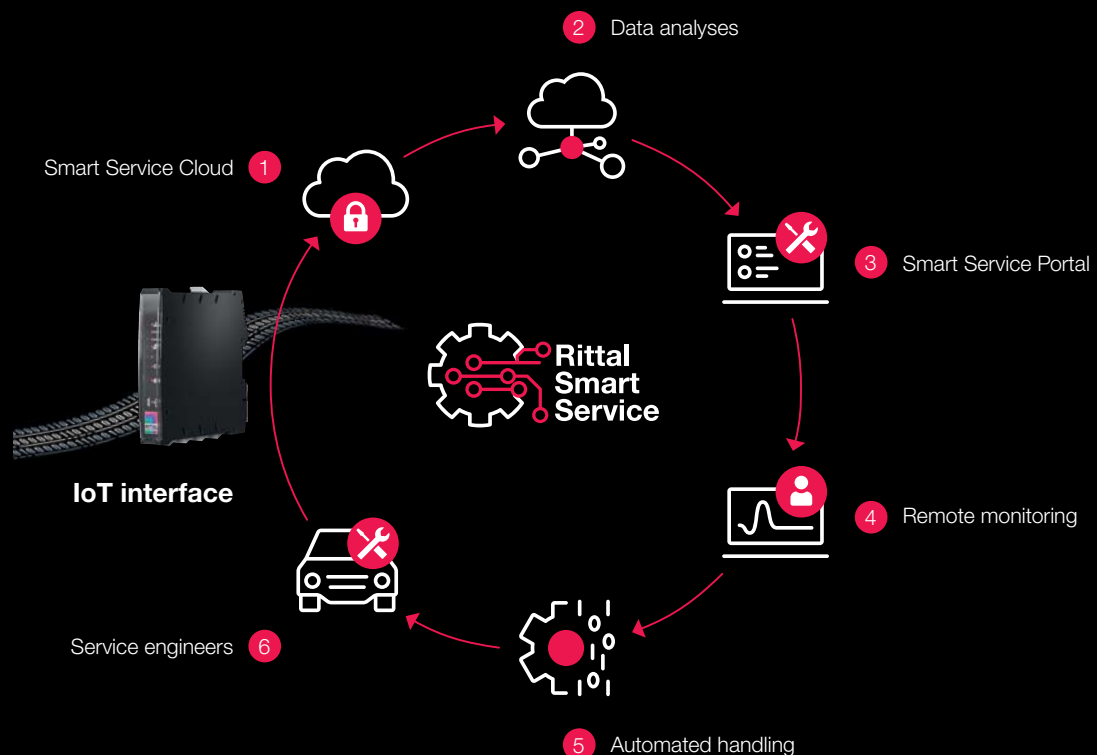

# Air/water heat exchangers



**Accessories for climate control** see Cat. 36, page 533 **Chillers** Page 18 **Therm software** Page 9

For use in harsh environments and temperature ranges up to +70 °C. User-friendly assembly plus flexible water connection options. External mounting or full internal mounting are supported.

**Colour:**

- RAL 7035

**Protection category IP to IEC 60 529:**

- IP 55

**Cooling medium:**

- Water (see Internet for specifications)

**Supply includes:**

- Fully wired ready for connection
- Drilling template
- Sealing and assembly parts

**Note:**

- Integral non-return valve for version with e-Comfort controller

**Approvals:**

Available on the Internet

**Performance diagrams:**

Available on the Internet

## Output class 300 – 600 W, wall-mounted

Model No.		Packs of	3212.024	3212.230	3363.100	3363.500	3214.100	Cat. 36, page
Design	Water-carrying parts, copper/brass (Cu/CuZn)							
Temperature control	Basic controller (factory setting +35 °C)		-	-	-	-	-	
	e-Comfort controller (factory setting +35 °C)		-	-	-	-	-	
	Thermostat-controlled magnetic valve		-	-	-	-	-	
<b>Total cooling output L35 W10, 200 l/h kW</b>			<b>0.3</b>	<b>0.3</b>	-	-	<b>0.6</b>	
<b>Total cooling output L35 W10, 400 l/h kW</b>			-	-	<b>0.5</b>	<b>0.5</b>	<b>0.7</b>	
Power consumption P <sub>el</sub> 50/60 Hz W			-	23 / 27	37 / 38	37 / 38	36 / 37	
Power consumption P <sub>el</sub> W			26	-	-	-	-	
Rated operating voltage V			24 (DC)	230, 1~, 50/60	230, 1~, 50/60	230, 1~, 50/60	230, 1~, 50/60	
Width mm			150	150	280	280	200	
Height mm			300	300	550	550	500	
Depth mm			85	85	120	120	100	
Rated max. current A			1.2	0.11 / 0.13	0.18 / 0.18	0.18 / 0.18	0.17 / 0.18	
Operating temperature range			+1 °C...+70 °C	+1 °C...+70 °C	+1 °C...+70 °C	+1 °C...+70 °C	+1 °C...+70 °C	
Setting range			-	-	+20 °C...+55 °C	+20 °C...+55 °C	+20 °C...+55 °C	
Water inlet temperature			+1 °C...+30 °C	+1 °C...+30 °C	+1 °C...+30 °C	+1 °C...+30 °C	+1 °C...+30 °C	
Water connection	1/2" connector sleeve		-	-	-	-	-	
	G 3/8" external thread		-	-	-	-	-	
	3/8" connector sleeve		-	-	-	-	-	
Permissible operating pressure (p) bar			1 - 10	1 - 10	1 - 10	1 - 10	1 - 10	
Air throughput of fans (unimpeded air flow), internal circuit 50/60 Hz m <sup>3</sup> /h			-	280 / 310	290 / 345	290 / 345	280 / 310	
Air throughput of fans (unimpeded air flow), internal circuit with DC m <sup>3</sup> /h			250	-	-	-	-	
Weight as delivered kg			3.2	3.2	8.0	8.0	7.0	

**Accessories**

Condensate hose	1 pc(s).	3301.610	3301.610	3301.612	3301.612	3301.612	544
Door-operated switch	1 pc(s).	4127.010	4127.010	4127.010	4127.010	4127.010	1024
Toroidal transformer		-	see page	see page	see page	see page	550
Flow regulator valve		see page	see page	see page	see page	see page	545

# Air/water heat exchangers

## Output class 950 – 1250 W, wall-mounted

Model No.		Packs of	3364.504	3364.100	3364.500	3215.100	Cat. 36, page
Design	Water-carrying parts, stainless steel (1.4571)			–	–	–	
	Water-carrying parts, copper/brass (Cu/CuZn)		–				
Temperature control	Basic controller (factory setting +35 °C)		–		–	–	
	e-Comfort controller (factory setting +35 °C)			–		–	
	Thermostat-controlled magnetic valve		–	–	–		
<b>Total cooling output L35 W10, 200 l/h kW</b>			–	–	–	<b>1.25</b>	
<b>Total cooling output L35 W10, 400 l/h kW</b>			<b>0.95</b>	<b>1</b>	<b>1</b>	<b>1.3</b>	
Power consumption P <sub>el</sub> 50/60 Hz W			37 / 38	37 / 38	37 / 38	83 / 85	
Power consumption P <sub>el</sub>			–	–	–	–	
Rated operating voltage V, ~, Hz			230, 1~, 50/60	230, 1~, 50/60	230, 1~, 50/60	230, 1~, 50/60	
Width mm			280	280	280	200	
Height mm			550	550	550	950	
Depth mm			120	120	120	100	
Rated max. current A			0.18 / 0.18	0.18 / 0.18	0.18 / 0.18	0.38 / 0.4	
Operating temperature range			+1 °C...+70 °C	+1 °C...+70 °C	+1 °C...+70 °C	+1 °C...+70 °C	
Setting range			+20 °C...+55 °C	+20 °C...+55 °C	+20 °C...+55 °C	+20 °C...+55 °C	
Water inlet temperature			+1 °C...+30 °C	+1 °C...+30 °C	+1 °C...+30 °C	+1 °C...+30 °C	
Water connection	½" connector sleeve						
	G ¾" external thread					–	
Permissible operating pressure (p) bar			1 - 10	1 - 10	1 - 10	1 - 10	
Air throughput of fans (unimpeded air flow), internal circuit 50/60 Hz m³/h			290 / 345	290 / 345	290 / 345	680 / 735	
Air throughput of fans (unimpeded air flow), internal circuit with DC			–	–	–	–	
Weight as delivered kg			9.0	9.0	9.0	13.0	
<b>Accessories</b>							
Condensate hose		1 pc(s).	3301.612	3301.612	3301.612	3301.612	544
Door-operated switch		1 pc(s).	4127.010	4127.010	4127.010	4127.010	1024
Toroidal transformer			see page	see page	see page	see page	550
Flow regulator valve			see page	see page	see page	see page	545

Rittal – The System.



## Connection set

see Cat. 36, page 545



# Air/water heat exchangers

## Output class 2000 – 2800 W, wall-mounted

Model No.		Packs of	3373.100	3373.140	3373.500	3374.504	Cat. 36, page
Design	Water-carrying parts, stainless steel (1.4571)		–	–	–	–	
	Water-carrying parts, copper/brass (Cu/CuZn)					–	
Temperature control	Basic controller (factory setting +35 °C)				–	–	
	e-Comfort controller (factory setting +35 °C)		–	–			
<b>Total cooling output L35 W10, 200 l/h</b>			–	–	–	–	
<b>Total cooling output L35 W10, 400 l/h kW</b>			<b>2</b>	<b>2</b>	<b>2</b>	<b>2.8</b>	
Power consumption P <sub>el</sub> 50/60 Hz W			110 / 140	110 / 140	110 / 140	169 / 232	
Power consumption P <sub>el</sub>			–	–	–	–	
Rated operating voltage V, ~, Hz			230, 1~, 50/60	400, 2~, 50/60	230, 1~, 50/60	230, 1~, 50/60	
Width mm			400	400	400	400	
Height mm			950	950	950	950	
Depth mm			145	145	145	145	
Rated max. current A			0.49 / 0.61	0.28 / 0.35	0.49 / 0.61	0.76 / 1.01	
Operating temperature range			+1 °C...+70 °C	+1 °C...+70 °C	+1 °C...+70 °C	+1 °C...+70 °C	
Setting range			+20 °C...+55 °C	+20 °C...+55 °C	+20 °C...+55 °C	+20 °C...+55 °C	
Water inlet temperature			+1 °C...+30 °C	+1 °C...+30 °C	+1 °C...+30 °C	+1 °C...+30 °C	
Water connection	½" connector sleeve						
	G ¾" external thread						
Permissible operating pressure (p) bar			1 - 10	1 - 10	1 - 10	1 - 10	
Air throughput of fans (unimpeded air flow), internal circuit 50/60 Hz m³/h			880 / 950	880 / 950	880 / 950	1150 / 1300	
Air throughput of fans (unimpeded air flow), internal circuit with DC			–	–	–	–	
Weight as delivered kg			20.0	23.0	20.0	23.0	
<b>Accessories</b>							
Condensate hose		1 pc(s).	3301.612	3301.612	3301.612	3301.612	544
Door-operated switch		1 pc(s).	4127.010	4127.010	4127.010	4127.010	1024
Toroidal transformer			–	–	–	–	
Flow regulator valve			see page	see page	see page	see page	545

## Output class 3000 W, wall-mounted

Model No.		Packs of	3374.100	3374.140	3374.500	3374.540	Cat. 36, page
Design	Water-carrying parts, copper/brass (Cu/CuZn)						
Temperature control	Basic controller (factory setting +35 °C)				–	–	
	e-Comfort controller (factory setting +35 °C)		–	–			
<b>Total cooling output L35 W10, 200 l/h</b>			–	–	–	–	
<b>Total cooling output L35 W10, 400 l/h kW</b>			<b>3</b>	<b>3</b>	<b>3</b>	<b>3</b>	
Power consumption P <sub>el</sub> 50/60 Hz W			169 / 232	169 / 232	169 / 232	169 / 232	
Power consumption P <sub>el</sub>			–	–	–	–	
Rated operating voltage V, ~, Hz			230, 1~, 50/60	400, 2~, 50/60	230, 1~, 50/60	400, 2~, 50/60	
Width mm			400	400	400	400	
Height mm			950	950	950	950	
Depth mm			145	145	145	145	
Rated max. current A			0.76 / 1.01	0.44 / 0.58	0.76 / 1.01	0.44 / 0.58	
Operating temperature range			+1 °C...+70 °C	+1 °C...+70 °C	+1 °C...+70 °C	+1 °C...+70 °C	
Setting range			+20 °C...+55 °C	+20 °C...+55 °C	+20 °C...+55 °C	+20 °C...+55 °C	
Water inlet temperature			+1 °C...+30 °C	+1 °C...+30 °C	+1 °C...+30 °C	+1 °C...+30 °C	
Water connection	½" connector sleeve						
	G ¾" external thread						
Permissible operating pressure (p) bar			1 - 10	1 - 10	1 - 10	1 - 10	
Air throughput of fans (unimpeded air flow), internal circuit 50/60 Hz m³/h			1150 / 1300	1150 / 1300	1150 / 1300	1150 / 1300	
Air throughput of fans (unimpeded air flow), internal circuit with DC			–	–	–	–	
Weight as delivered kg			23.0	26.0	23.0	26.0	
<b>Accessories</b>							
Condensate hose		1 pc(s).	3301.612	3301.612	3301.612	3301.612	544
Door-operated switch		1 pc(s).	4127.010	4127.010	4127.010	4127.010	1024
Toroidal transformer			–	–	–	–	
Flow regulator valve			see page	see page	see page	see page	545

# Air/water heat exchangers

## Output class 4500 – 5000 W, wall-mounted

Model No.		Packs of	3375.504	3375.100	3375.500	3375.540	Cat. 36, page
Design	Water-carrying parts, stainless steel (1.4571)			–	–	–	
	Water-carrying parts, copper/brass (Cu/CuZn)		–				
Temperature control	Basic controller (factory setting +35 °C)		–		–	–	
	e-Comfort controller (factory setting +35 °C)		–	–			
<b>Total cooling output L35 W10, 200 l/h</b>			–	–	–	–	
<b>Total cooling output L35 W10, 400 l/h kW</b>			<b>4.5</b>	<b>5</b>	<b>5</b>	<b>5</b>	
Power consumption P <sub>el</sub> 50/60 Hz W			172 / 172	172 / 172	172 / 172	183 / 183	
Power consumption P <sub>el</sub>			–	–	–	–	
Rated operating voltage V, ~, Hz			230, 1~, 50/60	230, 1~, 50/60	230, 1~, 50/60	400, 2~, 50/60	
Width mm			450	450	450	450	
Height mm			1400	1400	1400	1400	
Depth mm			220	220	220	220	
Rated max. current A			1.45 / 1.45	1.45 / 1.45	1.45 / 1.45	0.8 / 0.8	
Operating temperature range			+1 °C...+70 °C	+1 °C...+70 °C	+1 °C...+70 °C	+1 °C...+70 °C	
Setting range			+20 °C...+55 °C	+20 °C...+55 °C	+20 °C...+55 °C	+20 °C...+55 °C	
Water inlet temperature			+1 °C...+30 °C	+1 °C...+30 °C	+1 °C...+30 °C	+1 °C...+30 °C	
Water connection	½" connector sleeve						
	G ¾" external thread						
Permissible operating pressure (p) bar			1 - 10	1 - 10	1 - 10	1 - 10	
Air throughput of fans (unimpeded air flow), internal circuit 50/60 Hz m³/h			1500 / 1500	1500 / 1500	1500 / 1500	1500 / 1500	
Air throughput of fans (unimpeded air flow), internal circuit with DC			–	–	–	–	
Weight as delivered kg			39.0	39.0	39.0	42.0	
<b>Accessories</b>							
Condensate hose		1 pc(s).	3301.612	3301.612	3301.612	3301.612	544
Door-operated switch		1 pc(s).	4127.010	4127.010	4127.010	4127.010	1024
Toroidal transformer			–	–	–	–	
Flow regulator valve			see page	see page	see page	see page	545

**Rittal – The System.**



## Blue e+ chillers

see Cat. 36, page 522

# Air/water heat exchangers



**Accessories for climate control** see Cat. 36, page 533 **Chillers** Page 18 **Therm software** Page 9

For use in harsh environments and temperature ranges up to +70 °C. With thermostatically controlled magnetic valve.

**Colour:**  
– RAL 7035

**Protection category IP to IEC 60 529:**  
– IP 55

**Cooling medium:**  
– Water (see Internet for specifications)

**Supply includes:**  
– Fully wired ready for connection (plug-in terminal strip)  
– Drilling template  
– Sealing and assembly parts

**Note:**  
– Use 3-pole miniature circuit-breaker

**Approvals:**  
Available on the Internet

**Performance diagrams:**  
Available on the Internet

## Output class 7000 W, wall-mounted

Model No.		Packs of	3216.480	Cat. 36, page
Temperature control	Thermostat-controlled magnetic valve			
<b>Total cooling output L35 W10, 500 l/h kW</b>			<b>7</b>	
<b>Total cooling output L35 W20, 500 l/h kW</b>			<b>4.5</b>	
Rated operating voltage V, ~, Hz			400, 3~, 50/60 480, 3~, 60	
Width mm			450	
Height mm			1800	
Depth mm			300	
Rated max. current A			1.4 / 1.6	
Operating temperature range			+1 °C...+70 °C	
Setting range			+20 °C...+55 °C	
Water inlet temperature			+1 °C...+30 °C	
Water connection	½" connector sleeve			
	G ¾" external thread			
Permissible operating pressure (p) bar			1 - 10	
Air throughput of fans (unimpeded air flow), internal circuit 50/60 Hz m³/h			4075 / 4840	
Weight as delivered kg			79.0	
<b>Accessories</b>				
Door-operated switch		1 pc(s).	4127.010	1024
Condensate hose		1 pc(s).	3301.612	544
Flow regulator valve			see page	545
Connection set		1 pc(s).	3201.990	545
Cooling medium (ready-mixed)			see page	545

# Air/water heat exchangers



Accessories for climate control see Cat. 36, page 533 Chillers Page 18 Therm software Page 9 Hygienic Design HD Page 13

Air/water heat exchanger for hygienically sensitive production zones in the food and consumables industry – the optimum addition to the Rittal Hygienic Design range. The cleaning-friendly design reduces the risk of contamination and ensures food safety.

#### Benefits:

- Easy-to-clean, hygienic design
- A roof tilt of 30° prevents objects from being deposited on it, and allows liquids to run off quickly.
- All-round external, replaceable silicone seal prevents the accumulation of dirt between the enclosure and the air/water heat exchanger.

#### Material:

- Enclosures: Stainless steel 1.4301 (AISI 304)

#### Surface finish:

- Enclosure: Brushed, grain 400, peak-to-valley height < 0.8 µm

#### Protection category IP to IEC 60 529:

- IP 56/59

#### Protection category NEMA:

- NEMA 4X

#### Cooling medium:

- Water (see Internet for specifications)

#### Supply includes:

- Fully wired ready for connection
- Drilling template
- Sealing and assembly parts

#### Note:

- To achieve a protection category of IP 66/69 to IEC 60 529, the ingress of leakage air through the condensate discharge opening must be completely prevented.

#### Approvals:

Available on the Internet

#### Performance diagrams:

Available on the Internet

## Output class 600 – 1200 W, wall-mounted HD

Model No.		Packs of	3214.700	3215.700	Cat. 36, page
Temperature control	Thermostat-controlled magnetic valve				
<b>Total cooling output L35 W10, 200 l/h kW</b>			<b>0.6</b>	<b>1</b>	
<b>Total cooling output L35 W10, 400 l/h kW</b>			<b>0.65</b>	<b>1.2</b>	
Power consumption P <sub>el</sub> 50/60 Hz W			33 / 34	77 / 104	
Rated operating voltage V, ~, Hz			230, 1~, 50/60	230, 1~, 50/60	
Width mm			220	215	
Height mm			526	982	
Depth mm			100	100	
Rated max. current A			0.16 / 0.14	0.38 / 0.47	
Operating temperature range			+1 °C...+70 °C	+1 °C...+70 °C	
Setting range			+20 °C...+60 °C	+20 °C...+60 °C	
Water inlet temperature			+1 °C...+30 °C	+1 °C...+30 °C	
Water connection	G 3/8" external thread				
Permissible operating pressure (p) bar			1 - 10	1 - 10	
Air throughput of fans (unimpeded air flow), internal circuit 50/60 Hz m³/h			280 / 310	680 / 735	
Weight as delivered kg			6.0	14.0	
<b>Accessories</b>					
Toroidal transformer			see page	see page	550
Cooling medium (ready-mixed)			see page	see page	545

# Air/water heat exchangers



**Accessories for climate control** see Cat. 36, page 533 **Chillers** Page 18 **Air routing** Page 14

For use in harsh environments and temperature ranges up to +70 °C. The air/water heat exchanger is assembled on the roof of the enclosure using flexible water connection options.

**Colour:**

– RAL 7035

**Protection category IP to IEC 60 529:**

– IP 55

**Cooling medium:**

– Water (see Internet for specifications)

**Supply includes:**

- Fully wired ready for connection (plug-in terminal strip)
- Drilling template
- Sealing mat
- Assembly parts

**Approvals:**

Available on the Internet

**Performance diagrams:**

Available on the Internet

## Output class 1875 – 3000 W, roof-mounted

Model No.		Packs of	3209.504	3209.100	3209.500	3210.504	Cat. 36, page
Design	Water-carrying parts, stainless steel (1.4571)			–	–		
	Water-carrying parts, copper/brass (Cu/CuZn)		–			–	
Temperature control	Basic controller (factory setting +35 °C)		–		–	–	
	e-Comfort controller (factory setting +35 °C)			–			
<b>Total cooling output L35 W10, 400 l/h kW</b>			<b>1.87</b>	<b>2.5</b>	<b>2.5</b>	<b>3</b>	
Power consumption P <sub>el</sub> 50/60 Hz W			95 / 110	95 / 110	95 / 110	100 / 120	
Rated operating voltage V, ~, Hz			230, 1~, 50/60	230, 1~, 50/60	230, 1~, 50/60	230, 1~, 50/60	
Width mm			597	597	597	597	
Height mm			417	417	417	417	
Depth mm			475	475	475	475	
Rated max. current A			0.4 / 0.48	0.4 / 0.48	0.4 / 0.48	0.44 / 0.5	
Operating temperature range			+1 °C...+70 °C	+1 °C...+70 °C	+1 °C...+70 °C	+1 °C...+70 °C	
Setting range			+20 °C...+55 °C	+20 °C...+55 °C	+20 °C...+55 °C	+20 °C...+55 °C	
Water inlet temperature			+1 °C...+30 °C	+1 °C...+30 °C	+1 °C...+30 °C	+1 °C...+30 °C	
Water connection	½" connector sleeve						
	G ¾" external thread						
Permissible operating pressure (p) bar			1 - 10	1 - 10	1 - 10	1 - 10	
Air throughput of fans (unimpeded air flow), internal circuit 50/60 Hz m³/h			925 / 1030	925 / 1030	925 / 1030	815 / 925	
Weight as delivered kg			23.5	23.5	23.5	25.5	
<b>Accessories</b>							
Door-operated switch		1 pc(s).	4127.010	4127.010	4127.010	4127.010	1024
Master-slave cable		1 pc(s).	3124.100	–	3124.100	3124.100	550
Air duct system		1 pc(s).	3286.870	3286.870	3286.870	3286.870	540
Stoppers		2 pc(s).	3286.880	3286.880	3286.880	3286.880	542
Condensate hose		1 pc(s).	3301.612	3301.612	3301.612	3301.612	544
Cooling medium (ready-mixed)			see page	see page	see page	see page	545



# Air/water heat exchangers

## Output class 4000 W, roof-mounted

Model No.		Packs of	3210.100	3210.500	3210.540	Cat. 36, page
Design	Water-carrying parts, copper/brass (Cu/CuZn)					
Temperature control	Basic controller (factory setting +35 °C)			-	-	
	e-Comfort controller (factory setting +35 °C)		-			
<b>Total cooling output L35 W10, 400 l/h kW</b>			<b>4</b>	<b>4</b>	<b>4</b>	
Power consumption P <sub>el</sub> 50/60 Hz W			100 / 120	100 / 120	102 / 125	
Rated operating voltage V, ~, Hz			230, 1~, 50/60	230, 1~, 50/60	400, 2~, 50/60	
Width mm			597	597	597	
Height mm			417	417	417	
Depth mm			475	475	475	
Rated max. current A			0.44 / 0.5	0.44 / 0.5	0.25 / 0.3	
Operating temperature range			+1 °C...+70 °C	+1 °C...+70 °C	+1 °C...+70 °C	
Setting range			+20 °C...+55 °C	+20 °C...+55 °C	+20 °C...+55 °C	
Water inlet temperature			+1 °C...+30 °C	+1 °C...+30 °C	+1 °C...+30 °C	
Water connection	½" connector sleeve					
	G ¾" external thread					
Permissible operating pressure (p) bar			1 - 10	1 - 10	1 - 10	
Air throughput of fans (unimpeded air flow), internal circuit 50/60 Hz m³/h			815 / 925	815 / 925	815 / 925	
Weight as delivered kg			25.5	25.5	29.5	
<b>Accessories</b>						
Door-operated switch		1 pc(s).	4127.010	4127.010	4127.010	1024
Master-slave cable		1 pc(s).	-	3124.100	3124.100	550
Air duct system		1 pc(s).	3286.870	3286.870	3286.870	540
Stoppers		2 pc(s).	3286.880	3286.880	3286.880	542
Condensate hose		1 pc(s).	3301.612	3301.612	3301.612	544
Cooling medium (ready-mixed)			see page	see page	see page	545

**Rittal – The System.**



## VX25 TopTherm chillers

see Cat. 36, page 528

# Liquid Cooling Package



**Accessories for climate control** see Cat. 36, page 533 **Chillers** Page 18 **Therm software** Page 9 **LCP** Page 16

Air/water heat exchanger in the bayed enclosure system VX25. To fit 600 or 800 mm deep, 2000 mm high VX25 enclosures. Air outlet either with 5 kW on each side or 10 kW on one side only. Flexible options for water connection on the top or bottom of the unit.

**Temperature control:**

- e-Comfort controller (factory setting +35 °C)

**Colour:**

- RAL 7035

**Protection category IP to IEC 60 529:**

- IP 55

**Cooling medium:**

- Water (see Internet for specifications)

**Supply includes:**

- Cooling unit ready for connection, wired to terminal strip
- Front door with display
- Rear panel
- Multi-lingual documentation

**Note:**

- Bayable by screw-fastening at the sides

**Approvals:**

Available on the Internet

**Performance diagrams:**

Available on the Internet

## Output class 10000 W, LCP rack industry

Model No.	Packs of	3378.300	3378.380	Cat. 36, page
Design	Water-carrying parts, copper/brass (Cu/CuZn)			
<b>Total cooling output L35 W10, 2000 l/h kW</b>		<b>9.5</b>	<b>9.5</b>	
Power consumption P <sub>el</sub> 50/60 Hz W		350 / 350	350 / 350	
Rated operating voltage V, ~, Hz		230, 1~, 50/60	230, 1~, 50/60	
Width mm		300	300	
Height mm		2000	2000	
Depth mm		600	800	
Rated max. current A		2.65 / 2.62	2.65 / 2.62	
Operating temperature range		+5 °C...+70 °C	+5 °C...+70 °C	
Setting range		+20 °C...+55 °C	+20 °C...+55 °C	
Water inlet temperature		+7 °C...+30 °C	+7 °C...+30 °C	
Water connection	G ¾" internal thread			
Permissible operating pressure (p) bar		1 - 6	1 - 6	
Air throughput of fans (unimpeded air flow), internal circuit 50/60 Hz m³/h		1950 / 1950	1950 / 1950	
Weight as delivered kg		106.0	115.0	

**Accessories**

Base/plinth corner pieces with base/plinth trim panels, front and rear, 100 mm	2 pc(s).	8640.000	8640.000	881
Base/plinth trim panels, sides, 100 mm	2 pc(s).	8640.033	8640.034	882
Base/plinth corner pieces with base/plinth trim panels, front and rear, 200 mm	2 pc(s).	8640.020	8640.020	881
Base/plinth trim panels, sides, 200 mm	2 pc(s).	8640.043	8640.044	882
Baying connector, external	6 pc(s).	8617.502	8617.502	912
Side panel, screw-fastened, sheet steel	2 pc(s).	8106.245	8108.245	901
Condensate hose	1 pc(s).	3301.612	3301.612	544
Speed control EC	1 pc(s).	3235.440	3235.440	548
Comfort handle VX	1 pc(s).	8618.250	8618.250	937
Master-slave cable	1 pc(s).	3124.100	3124.100	550
Cooling medium (ready-mixed)		see page	see page	545



**Accessories for climate control** see Cat. 36, page 533 **Chiller configurator** Page 9

#### Design:

- Compact, modular layout of the refrigeration components
- Nano-coated condenser
- Pump to convey the medium

#### Benefits:

- Precise temperature control, based on microprocessor technology
- Collective fault signal with floating contact
- One version for two frequencies = international compatibility

#### Temperature control:

- Microcontroller control (factory setting +20 °C)

#### Colour:

- RAL 7035

#### Protection category IP to IEC 60 529:

- IP 44 (electrics)

#### Supply includes:

- Complete unit ready for connection
- Multilingual documentation including functional diagram and wiring plans

#### Characteristic curves of pump:

Available on the Internet

#### Approvals:

Available on the Internet

## Output class 1000 – 1500 W

Model No.	Packs of	3318.610	3319.610	Cat. 36, page
<b>Total cooling output at <math>T_w = 18^\circ\text{C} / T_u = 35^\circ\text{C}</math> to DIN EN 14511 kW</b>		<b>0.98 / 1.07</b>	<b>1.47 / 1.66</b>	
Total cooling output at $T_w = 10^\circ\text{C} / T_u = 32^\circ\text{C}$ kW		0.8 / 0.9	1.2 / 1.3	
Total cooling output at $T_w = 18^\circ\text{C} / T_u = 32^\circ\text{C}$ kW		1 / 1.1	1.5 / 1.7	
Power consumption $P_{el}$ 50/60 Hz kW		0.69 / 1.07	0.86 / 0.99	
Rated operating voltage V, ~, Hz		230, 1~, 50/60	230, 1~, 50/60	
Width mm		600	600	
Height mm		400	400	
Depth mm		455	455	
Rated max. current A		5.1 / 5.6	5.7 / 5.6	
Operating temperature range		+10 °C...+43 °C	+10 °C...+43 °C	
Refrigerant kg		R134a, 0.975	R134a, 0.975	
Water connection	G ½" internal thread			
Pump pressure bar		2.5	2.5	
Volumetric flow (cooling medium) l/min		4 / 6	4 / 6	
Air throughput of fans (unimpeded air flow), 50/60 Hz m³/h		900 / 900	900 / 900	
Temperature hysteresis		± 2 K	± 2 K	
Temperature of liquid		+10 °C...+30 °C	+10 °C...+30 °C	
Water circuit version		hermetically open	hermetically open	
Tank		PP plastic	PP plastic	
Tank capacity l		2.5	2.5	
Weight as delivered kg		48.0	51.0	
<b>Also required</b>				
Cooling medium (ready-mixed)		see page	see page	545
<b>Accessories</b>				
Metal filter	1 pc(s).	3286.510	3286.510	534

# Blue e+ chillers



Accessories for climate control see Cat. 36, page 533 Chiller configurator Page 9 IoT interface Page 23 Blue e+ chillers Page 23

## Benefits:

- Blue e+ chillers ensure centralised and efficient cooling of liquid media with a high level of temperature accuracy and innovative DC inverter technology
- Suitable for international use thanks to its unique multi-voltage capability (without rewiring) and high operating limits
- Maximum reliability thanks to integral overflow valve and monitoring sensors
- Intuitive operation with touch display and intelligent interfaces
- Compact and modular layout ensures minimum footprint
- Pumps with highly efficient IE3 motors

## Temperature control:

- e+ controller (factory setting +20 °C)

## Colour:

- Textured RAL 7035

## Protection category IP to IEC 60 529:

- IP 24

## Supply includes:

- Complete unit ready for connection (plug-in terminal strip)
- Multi-lingual documentation

## Optional:

- For remote monitoring and networking of cooling units and chillers in the Blue e+ generation, please use the IoT interface (Model No. 3124.300). Increase machine availability and process reliability with remote monitoring of device data, statuses and system messages.

## Approvals:

Available on the Internet

## Performance diagrams:

Available on the Internet

## Output class 2500 – 5500 W

Model No.	Packs of	3320.200	3334.300	3334.400	Cat. 36, page
<b>Total cooling output at <math>T_w = 18\text{ °C}/T_u = 35\text{ °C}</math> to DIN EN 14511 kW</b>		<b>2.5 / 2.4</b>	<b>4 / 3.9</b>	<b>5.5 / 5.4</b>	
Total cooling output at $T_w = 10\text{ °C}/T_u = 32\text{ °C}$ kW		1.81 / 1.71	2.87 / 2.77	4.33 / 4.23	
Total cooling output at $T_w = 18\text{ °C}/T_u = 32\text{ °C}$ kW		2.61 / 2.51	4.18 / 4.08	5.72 / 5.62	
Power consumption $P_{el}$ 50/60 Hz kW		1.38 / 1.57	2.49 / 2.72	2.49 / 2.72	
Rated operating voltage $V_n$ , ~, Hz		380 - 415, 3~, 50 440 - 480, 3~, 60	380 - 415, 3~, 50 440 - 480, 3~, 60	380 - 415, 3~, 50 440 - 480, 3~, 60	
Width mm		450	450	450	
Height mm		820	820	1000	
Depth mm		710	710	710	
Rated max. current A		2.17 / 1.95	3.95 / 3.47	3.95 / 3.47	
Operating temperature range		-5 °C...+50 °C	-5 °C...+50 °C	-5 °C...+50 °C	
Refrigerant kg		R134a, 0.46	R134a, 0.76	R134a, 0.93	
Water connection	¾" internal thread				
Pump pressure bar		2.4	2.9	2.9	
Volumetric flow (cooling medium) l/min		7 / 25	15 / 30	15 / 30	
Temperature hysteresis		± 0.5 K	± 0.5 K	± 0.5 K	
Temperature of liquid		+5 °C...+35 °C	+5 °C...+35 °C	+5 °C...+35 °C	
Water circuit version		hermetically open	hermetically open	hermetically open	
Tank		PE plastic	PE plastic	PE plastic	
Tank capacity l		12	12	12	
Weight as delivered kg		84.0	90.0	96.0	
<b>Also required</b>					
Cooling medium (ready-mixed)		see page	see page	see page	545
<b>Accessories</b>					
Filter mat for cooling units, air/air heat exchangers and chillers	3 pc(s).	3285.920	3285.920	3285.900	533
Filter mat for Blue e+ chillers (inverter housings)	3 pc(s).	3285.940	3285.940	3285.940	533
Metal filter	1 pc(s).	3285.930	3285.930	3285.910	534
IoT interface	1 pc(s).	3124.300	3124.300	3124.300	554
RiDiag	1 pc(s).	3159.300	3159.300	3159.300	559
Temperature sensor	1 pc(s).	3124.400	3124.400	3124.400	549
Cross member	2 pc(s).	8601.680	8601.680	8601.680	891
Levelling feet	4 pc(s).	4612.000	4612.000	4612.000	892
Twin castors	1 pc(s).	6148.000	6148.000	6148.000	893
Flow regulator valve		see page	see page	see page	545

Rittal – The System.



**IoT interface**

see Cat. 36, page 554



# Blue e chillers



Accessories for climate control see Cat. 36, page 533 Cooling medium Page 19 Blue e chillers Page 24

Blue e chillers with their high level of precision cooling ensure maximum efficiency and uptime for your systems – and that whilst using 40% less refrigerant. We offer an extended range covering all standard output classes with fast, off-the-shelf availability.

#### Benefits:

- Microchannel technology reduces the volume of refrigerant required
- Touch display for simplified user guidance
- Intelligent interfaces
- Integrated safety functions
- Pre-configured options

#### Colour:

- Enclosure: RAL 7035
- Base/plinth: RAL 7016

#### Protection category IP to IEC 60 529:

- IP 44 (electrics)

#### Supply includes:

- Chiller wired ready for connection
- Multilingual documentation including functional diagram and wiring plans

#### Approvals:

Available on the Internet

## Output class 8000 – 15000 W

Model No.	Packs of	3336.390	3336.400	3336.405	3336.410	3336.415	Cat. 36, page
<b>Total cooling output at <math>T_w = 18\text{ °C}/T_u = 35\text{ °C}</math> to DIN EN 14511 kW</b>		<b>7.35 / 8.68</b>	<b>11.01 / 12.67</b>	<b>11.01 / 12.67</b>	<b>13.86 / 14.36</b>	<b>13.86 / 14.36</b>	
Total cooling output at $T_w = 10\text{ °C}/T_u = 32\text{ °C}$ kW		6 / 7.3	10.2 / 11.7	10.2 / 11.7	12.2 / 12.3	12.2 / 12.3	
Total cooling output at $T_w = 18\text{ °C}/T_u = 32\text{ °C}$ kW		7.8 / 9.3	11.8 / 13.2	11.8 / 13.2	14.3 / 14.8	14.3 / 14.8	
Power consumption $P_{el}$ 50/60 Hz kW		4.18 / 5.26	6.3 / 8.8	6.3 / 8.8	7.02 / 8.75	7.7 / 9.9	
Rated operating voltage V, ~, Hz		400, 3~, 50 460, 3~, 60	400, 3~, 50 460, 3~, 60	400, 3~, 50 460, 3~, 60	400, 3~, 50 460, 3~, 60	400, 3~, 50 460, 3~, 60	
Width mm		595	660	660	660	660	
Height mm		1180	1265	1265	1265	1265	
Depth mm		800	1315	1315	1315	1315	
Rated max. current A		7.60 / 8.16	10.2 / 11.3	11.1 / 13.1	12.9 / 12.9	13.8 / 14.65	
Performance-enhanced pump		–	–	–	–	–	
Control voltage 24 V DC		–	–	–	–	–	
Precision controller		–	–	–	–	–	
Operating temperature range		+10 °C...+43 °C	+10 °C...+43 °C	+10 °C...+43 °C	+10 °C...+43 °C	+10 °C...+43 °C	
Refrigerant kg		R410A, 950	R410A, 1.35	R410A, 1.35	R410A, 1.35	R410A, 1.35	
Water connection	R ¾" internal thread	–	–	–	–	–	
	R 1" internal thread	–	–	–	–	–	
Pump pressure bar		3 / 4.5	2 / 2	5 / 7	2 / 2	5 / 7	
Volumetric flow (cooling medium) l/min		22 / 25	30 / 55	30 / 55	35 / 55	35 / 55	
Air throughput of fans (unimpeded air flow), 50/60 Hz m³/h		6000 / 7200	6000 / 7200	6000 / 7200	6000 / 7200	6000 / 7200	
Temperature hysteresis		± 2 K	± 2 K	± 0.25 K	± 2 K	± 0.25 K	
Temperature of liquid		+10 °C...+25 °C	+10 °C...+25 °C	+10 °C...+25 °C	+10 °C...+25 °C	+10 °C...+25 °C	
Tank		PE plastic	PE plastic	PE plastic	PE plastic	PE plastic	
Tank capacity l		30	49	49	49	49	
Weight as delivered kg		316.0	247.0	247.0	253.0	253.0	
<b>Accessories</b>							
Cooling medium (ready-mixed)		see page	see page	see page	see page	see page	545
Metal filter	2 pc(s).	3286.580	3286.560	3286.560	3286.560	3286.560	534

## Output class 20000 – 25000 W

Model No.	Packs of	3336.430	3336.435	3336.450	3336.455	Cat. 36, page
<b>Total cooling output at <math>T_w = 18\text{ °C}/T_u = 35\text{ °C}</math> to DIN EN 14511 kW</b>		<b>18.45 / 21.44</b>	<b>18.45 / 21.44</b>	<b>22.93 / 25.29</b>	<b>22.93 / 25.29</b>	
Total cooling output at $T_w = 10\text{ °C}/T_u = 32\text{ °C}$ kW		16.3 / 19.2	16.3 / 19.2	19.9 / 22.9	19.9 / 22.9	
Total cooling output at $T_w = 18\text{ °C}/T_u = 32\text{ °C}$ kW		19.3 / 22	19.3 / 22	24.4 / 26.3	24.4 / 26.3	
Power consumption $P_{el}$ 50/60 Hz kW		8.5 / 10.9	8.5 / 10.9	10.6 / 13.3	11.3 / 14.4	
Rated operating voltage V, ~, Hz		400, 3~, 50 460, 3~, 60	400, 3~, 50 460, 3~, 60	400, 3~, 50 460, 3~, 60	400, 3~, 50 460, 3~, 60	
Width mm		760	760	760	760	
Height mm		1265	1265	1265	1265	
Depth mm		1515	1515	1515	1515	
Rated max. current A		19 / 15.9	19.9 / 17.2	21.7 / 22.4	22.6 / 24.1	
Performance-enhanced pump		-	-	-	-	
Control voltage 24 V DC		-	-	-	-	
Precision controller		-	-	-	-	
Operating temperature range		+10 °C...+43 °C	+10 °C...+43 °C	+10 °C...+43 °C	+10 °C...+43 °C	
Refrigerant kg		R410A, 1.45	R410A, 1.45	R410A, 1.45	R410A, 1.45	
Water connection	R 1¼" internal thread					
Pump pressure bar		2 / 2	4.75 / 6.75	2 / 2	4.5 / 6.7	
Volumetric flow (cooling medium) l/min		45 / 75	45 / 75	55 / 75	55 / 75	
Air throughput of fans (unimpeded air flow), 50/60 Hz m³/h		12000 / 14500	12000 / 14500	12000 / 14500	12000 / 14500	
Temperature hysteresis		± 2 K	± 0.25 K	± 2 K	± 0.25 K	
Temperature of liquid		+10 °C...+25 °C	+10 °C...+25 °C	+10 °C...+25 °C	+10 °C...+25 °C	
Tank		PE plastic	PE plastic	PE plastic	PE plastic	
Tank capacity l		78	78	78	78	
Weight as delivered kg		310.0	310.0	326.0	326.0	
<b>Accessories</b>						
Cooling medium (ready-mixed)		see page	see page	see page	see page	545
Metal filter	2 pc(s).	3286.570	3286.570	3286.570	3286.570	534

## Output class 30000 – 50000 W

Model No.	Packs of	3336.460	3336.470	3336.480	Cat. 36, page	
<b>Total cooling output at <math>T_w = 18\text{ °C}/T_u = 35\text{ °C}</math> to DIN EN 14511 kW</b>		<b>30.8 / 35.9</b>	<b>36.5 / 46.6</b>	<b>44.7 / 50.5</b>		
Total cooling output at $T_w = 10\text{ °C}/T_u = 32\text{ °C}$ kW		28.1 / 33.2	29.7 / 35.7	39.1 / 44.4		
Total cooling output at $T_w = 18\text{ °C}/T_u = 32\text{ °C}$ kW		32.4 / 37.3	37.8 / 45.1	47.4 / 52.2		
Power consumption $P_{el}$ 50/60 Hz kW		12.69 / 16.15	16.6 / 21.2	20.3 / 25.5		
Rated operating voltage V, ~, Hz		400, 3~, 50 460, 3~, 60	400, 3~, 50 460, 3~, 60	400, 3~, 50 460, 3~, 60		
Width mm		900	900	900		
Height mm		1733	1733	1733		
Depth mm		1560	1560	1560		
Rated max. current A		22.98 / 24.43	29.7 / 32.7	36.1 / 37.7		
Performance-enhanced pump		-	-	-		
Control voltage 24 V DC		-	-	-		
Precision controller		-	-	-		
Operating temperature range		+10 °C...+43 °C	+10 °C...+43 °C	+10 °C...+43 °C		
Refrigerant kg		R410A, 4.0	R410A, 2.9	R410A, 2.9		
Water connection	R 1½" internal thread					
Pump pressure bar		2	2	2		
Volumetric flow (cooling medium) l/min		93 / 111	115 / 130	140 / 160		
Air throughput of fans (unimpeded air flow), 50/60 Hz m³/h		12000 / 14500	12000 / 14500	12000 / 14500		
Temperature hysteresis		± 2 K	± 2 K	± 2 K		
Temperature of liquid		+10 °C...+25 °C	+10 °C...+25 °C	+10 °C...+25 °C		
Tank		PE plastic	PE plastic	PE plastic		
Tank capacity l		150	150	150		
Weight as delivered kg		404	675	725		
<b>Accessories</b>						
Cooling medium (ready-mixed)		see page	see page	see page	545	
Metal filter	2 pc(s).	3286.590	3286.590	3286.590	534	

# VX25 TopTherm chillers



Accessories for climate control see Cat. 36, page 533 Chiller configurator Page 9 VX25 TopTherm chillers Page 26

VX25 TopTherm chillers are compact in design yet have a wide range of cooling applications. They fit perfectly with all enclosures; they have a minimum footprint; promise increased efficiency; are instantly available from stock.

#### Benefits:

- Up to 35% smaller CO<sub>2</sub> footprint
- Microchannel technology reduces the volume of refrigerant required
- Enhanced safety with integrated safety features
- Minimum footprint
- A single housing size for four output classes
- Extremely maintenance-friendly
- Smart interfaces

#### Temperature control:

- e-controller (factory setting +18 °C)

#### Colour:

- RAL 7035

#### Protection category IP to IEC 60 529:

- IP 44 (electrics)

#### Supply includes:

- Fully wired unit ready for connection with side panels and door

#### Note:

- Regular leak tests are not prescribed by law.

#### Characteristic curves of pump:

Available on the Internet

#### Approvals:

Available on the Internet

## Output class 8000 – 12000 W

Model No.	Packs of	3335.930	3335.940	Cat. 36, page
<b>Total cooling output at T<sub>w</sub> = 18 °C/T<sub>u</sub> = 35 °C to DIN EN 14511 kW</b>		<b>7.8 / 8.4</b>	<b>11.7 / 12.7</b>	
Total cooling output at T <sub>w</sub> = 10 °C/T <sub>u</sub> = 32 °C kW		6.5 / 7.5	10.3 / 11.3	
Total cooling output at T <sub>w</sub> = 18 °C/T <sub>u</sub> = 32 °C kW		8 / 8.6	12 / 13.1	
Power consumption P <sub>el</sub> 50/60 Hz kW		4.65 / 5.71	6.35 / 7.31	
Rated operating voltage V, ~, Hz		400, 3~, 50 460, 3~, 60	400, 3~, 50 460, 3~, 60	
Width mm		808	808	
Height mm		2113	2113	
Depth mm		608	608	
Rated max. current A		9 / 8.3	9.9 / 10.8	
Operating temperature range		+10 °C...+43 °C	+10 °C...+43 °C	
Refrigerant kg		R410A, 1.2	R410A, 1.4	
Water connection	R 1" internal thread			
Pump pressure bar		2.5 / 2.5	2.5 / 2.5	
Volumetric flow (cooling medium) l/min		30 / 47	30 / 55	
Temperature hysteresis		± 1.0 K	± 1.0 K	
Temperature of liquid		+10 °C...+25 °C	+10 °C...+25 °C	
Tank		PP plastic	PP plastic	
Tank capacity l		75	75	
Weight as delivered kg		323	357	
<b>Accessories</b>				
Metal filter	1 pc(s).	3286.630	3286.630	
Cooling medium (ready-mixed)		see page	see page	545
Flow regulator valve		see page	see page	545
Comfort handle VX	1 pc(s).	8618.250	8618.250	937
Twin castors	1 pc(s).	7495.000	7495.000	893
Base/plinth corner pieces with base/plinth trim panels, front and rear, 100 mm	2 pc(s).	8640.003	8640.003	881
Base/plinth trim panel, side, 100 mm	2 pc(s).	8640.033	8640.033	882
Base/plinth corner pieces with base/plinth trim panels, front and rear, 200 mm	2 pc(s).	8640.023	8640.023	881
Base/plinth trim panel, side, 200 mm	2 pc(s).	8640.043	8640.043	882

# VX25 TopTherm chillers

## Output class 16000 – 25000 W

Model No.	Packs of	3335.950	3335.960	Cat. 36, page
<b>Total cooling output at <math>T_w = 18\text{ °C}/T_u = 35\text{ °C}</math> to DIN EN 14511 kW</b>		<b>15.6 / 17</b>	<b>19.4 / 21.2</b>	
Total cooling output at $T_w = 10\text{ °C}/T_u = 32\text{ °C}$ kW		12.8 / 15.2	16.6 / 18.7	
Total cooling output at $T_w = 18\text{ °C}/T_u = 32\text{ °C}$ kW		16 / 17.6	20.0 / 21.8	
Power consumption $P_{el}$ 50/60 Hz kW		7.05 / 8.71	10.89 / 13.49	
Rated operating voltage V, ~, Hz		400, 3~, 50 460, 3~, 60	400, 3~, 50 460, 3~, 60	
Width mm		808	808	
Height mm		2113	2238	
Depth mm		608	608	
Rated max. current A		12.6 / 12.3	20.5 / 20.9	
Operating temperature range		+10 °C...+43 °C	+10 °C...+43 °C	
Refrigerant kg		R410A, 1.4	R410A, 2.2	
Water connection	R 1" internal thread			
Pump pressure bar		2.5 / 2.5	2.5 / 2.5	
Volumetric flow (cooling medium) l/min		35 / 63	43 / 76	
Temperature hysteresis		± 1.0 K	± 1.0 K	
Temperature of liquid		+10 °C...+25 °C	+10 °C...+25 °C	
Tank		PP plastic	PP plastic	
Tank capacity l		75	75	
Weight as delivered kg		357	370	
<b>Accessories</b>				
Metal filter	1 pc(s).	3286.630	3286.630	
Cooling medium (ready-mixed)		see page	see page	545
Flow regulator valve		see page	see page	545
Comfort handle VX	1 pc(s).	8618.250	8618.250	937
Twin castors	1 pc(s).	7495.000	7495.000	893
Base/plinth corner pieces with base/plinth trim panels, front and rear, 100 mm	2 pc(s).	8640.003	8640.003	881
Base/plinth trim panel, side, 100 mm	2 pc(s).	8640.033	8640.033	882
Base/plinth corner pieces with base/plinth trim panels, front and rear, 200 mm	2 pc(s).	8640.023	8640.023	881
Base/plinth trim panel, side, 200 mm	2 pc(s).	8640.043	8640.043	882

Rittal – The System.



## Chiller configurator

[www.rittal.com/chiller-configurator](http://www.rittal.com/chiller-configurator)

# Rittal – The System.

Faster – better – everywhere.

- Enclosures
- Power Distribution
- Climate Control
- IT Infrastructure
- Software & Services

You can find the contact details of all Rittal companies throughout the world here.



[www.rittal.com/contact](http://www.rittal.com/contact)

X1WW00025EN2000

ENCLOSURES

POWER DISTRIBUTION

CLIMATE CONTROL

IT INFRASTRUCTURE

SOFTWARE & SERVICES



FRIEDHELM LOH GROUP